



CBF25M - CBF25H - CBF25J - CBF25I

Specifications

Hand pallet truck

2.5 tonnes





Hand pallet truck

The hand pallet truck is without any doubt the most basic, yet essential, tool in materials handling. For decades, it has served as the “first assistant” for truck operators loading and unloading pallets on location.

In warehouses, shops and industry, hand pallet trucks are used in all kinds of applications and are particularly suited to short distance and occasional horizontal pallet handling.

Cat hand pallet trucks are durable, maneuverable, ergonomic and easy to maintain over a long service life, taking care of your business and your people.

Find out how our range of hand pallet trucks could work for you

Your Cat Lift Trucks dealer can give you more specific information about the hand pallet truck and also our full range of warehouse equipment and lift trucks, with capacities up to 16 tonnes. They'll advise you on the right equipment for your needs and how to maximize your return on investment.

Characteristics			Cat Lift Trucks	Cat Lift Trucks	Cat Lift Trucks	Cat Lift Trucks
			CBF25M	CBF25H	CBF25J	CBF25I
1.01	Manufacturer (abbreviation)		Pedestrian	Pedestrian	Pedestrian	Pedestrian
1.02	Manufacturer's model designation					
1.04	Operator type: pedestrian, (operator)-standing, -seated					
1.05	Load capacity	Q (kg)	2500	2500	2500	2500
1.06	Load center distance	c (mm)	600	600	600	600
1.08	Load wheels axle to fork face (forks lowered)	x (mm)	883	883	953	733
1.09	Wheelbase	y (mm)	1190	1190	1260	1040
Weight						
2.01	Truck weight without nominal load	kg	65	70	80	60
Wheels, chassis						
3.01	Tyre type: P=Polyurethane, N=Nylon, R=Rubber		P,N,R	P,N,R	P,N,R	P
3.02	Tyre dimension, drive side	Ø (mm)	200	200	200	200
3.03	Tyre dimension, load side	Ø (mm)	80	80	80	80
3.05	Number of wheels, drive/load side (x=driven)		1/2x1 - 1/2x2	1/2x1 - 1/2x2	1/2x1 - 1/2x2	1/2x1 - 1/2x3
3.06	Track width (center of tyres, drive side)	b10 (mm)	109	109	109	109
3.07	Track width (center of tyres), load side	b11 (mm)	370	370	370	370
Dimensions						
4.04	Lift height	h3 (mm)	85	85	85	85
4.09	Height of Tiller Arm /Steering console	h14 (mm)	1533	1533	1603	1383
4.15	Fork height fully lowered	h13 (mm)	384	384	384	384
4.19	Overall length	l1 (mm)	520	685	685	685
4.20	Length to fork face	l2 (mm)	45/160/1150	45/160/1150	45/160/1220	45/160/1000
4.21	Overall width	b1/b2 (mm)	520	685	685	685
4.22	Fork dimensions (thickness, width and length)	s/e/l (mm)	40	40	40	40
4.25	Outside width over forks	b5 (mm)	1516	1516	1517	1516
4.32	Ground clearance at centre of wheelbase (forks lowered)	m2 (mm)	1716	1716	1717	1716
4.33	Working aisle width (Ast3) with 1000 x1200 pallets, load crosswise	Ast3 (mm)	1266	1266	1336	1166
4.34	Working aisle width (Ast3) with 800 x1200 pallets, load lengthwise	Ast3 (mm)	115	115	115	115
4.35	Turning circle radius	Wa (mm)	1224	1224	1224	1224

* Fork length 1150mm, width over forks 520mm
 1 Galvanized
 2 Stainless steel
 3 High Lift

Model	Fork dimensions WxL (mm)	Load wheels	Steering wheel
CBF25M NSN	520 x 1150	2 Single, Nylon	Nylon
CBF25M NTN		4 Tandem, Nylon	
CBF25M PSP		2 Single, Polyurethane	Polyurethane
CBF25M PTP		4 Tandem, Polyurethane	
CBF25H NSN	685 x 1150	2 Single, Nylon	Nylon
CBF25H PSP		2 Single, Polyurethane	Polyurethane
CBF25H PTP		4 Tandem, Polyurethane	
CBF25J NSN	685 x 1220	2 Single, Nylon	Nylon
CBF25J NTN		4 Tandem, Nylon	
CBF25J PTP		4 Tandem, Polyurethane	Polyurethane
CBF25I PTP	685 x 1000	4 Tandem, Polyurethane	Polyurethane



CBF hand pallet truck

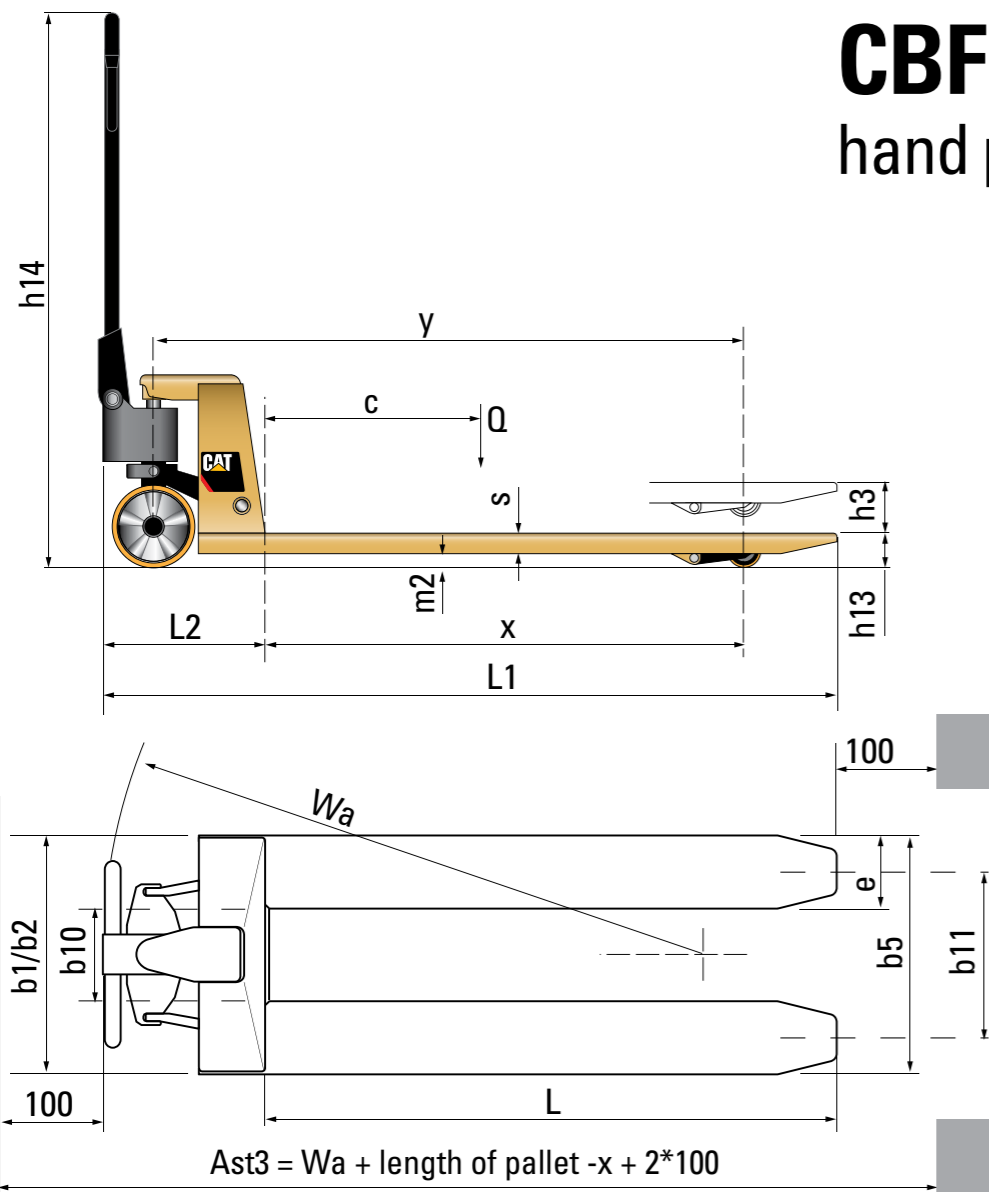

Hand pallet truck

Lower Cost of Ownership

- Competitive pricing
- 12 greasing nipples on all moving parts resulting in less wear
- Bypass valve preventing over load
- Bullet connection between steering shaft and pump piston
- Convenient to replace the steering wheel

Unmatched Productivity

- Easy to maneuver with 210° steering angle
- Special lowering valve to control the rate of descent
- Rollers mounted on fork tips for effortless entry/exit to/from pallet

Safety and Ergonomics

- Large rubber handle with 3 positions for control lever

Options

- Nylon- or rubber steering wheel
- Tandem load wheels



Cat® Lift Trucks.

Your partner in materials handling.



For over 80 years Caterpillar has built some of the world's best construction and mining equipment, designed to perform in the toughest environments.

This same philosophy and heritage is evident in our materials handling equipment, which includes a complete range of electric, diesel and LPG powered lift trucks and warehouse equipment.

Every day our dealer network delivers tailored materials handling solutions in more than 70 Countries across Europe, Africa and the Middle East.

We continually invest in the selection, development and support of our dealer network to provide you with the right equipment, service and advice. For instance, we offer the highest parts availability in the industry of over 97%, measured full line first pick, with next day delivery in most Countries.

Come and talk to us about your materials handling requirements.

Contact your dealer now or visit our website:

www.catliftruck.com.

Cat Lift Trucks.

PERFORMANCE DURABILITY CUSTOMER SERVICE

info@catliftruck.com

www.catliftruck.com

WESC1535(11/13)ok

©2013, MCFE. All rights reserved.

CAT, CATERPILLAR their respective logos, 'Caterpillar Yellow' and the 'Power Edge' trade dress, as well as corporate and product identity used herein, are trademarks of Caterpillar and may not be used without permission.

Printed in The Netherlands

NOTE: Performance specifications may vary depending on standard manufacturing tolerances, vehicle condition, types of tyres, floor or surface conditions, applications, or operating environment. Trucks may be shown with non-standard options. Specific performance requirements and locally available configurations should be discussed with your Cat lift trucks Dealer. Cat Lift Trucks follows a policy of continual product improvement. For this reason, some materials, options and specifications could change without notice.

